

VAN BUREN YOUTH FAIR

2024 Horse Pattern Book



Horse Show Superintendent: Terri Tripp-Novotny

Barn Superintendent: Kevin Novotny

Horse Committee President: Jennifer Chandler

Vice-President: Terri Tripp-Novotny

Secretary: Michelle Miersma

Treasurer: Joe Gladysz

Thank You Class Sponsors!

**Special thanks to Millbrook Tack for
helping with the Versatility Belt Buckles**

Volunteers Needed!

**The Horse Committee needs
volunteers to join the committee.**

Van Buren Youth Fair

SPEED AND ACTION

Class #492, #493, #494, #495, #496

Show Date: July 15, 2024

1. Seven kegs or markers are needed (see fig. 26). Using four of the kegs or markers, form a 12-foot by 24-foot box and mark lime lines between the kegs or markers on the 24-foot side. One 12-foot side will be on the starting line. The three remaining kegs or markers are to be placed at 7-foot intervals (from center to center) in a straight line parallel to and 200 feet from the starting line. These three kegs or markers must be at least 25 feet away from any fence.
2. The horse and rider are to start and end the course completely within the box. They may also start the course by entering through the top of the box (that is, by running through the box). Timing begins when the entry leaves the box and stops when the entry re-enters the box. The rider rides through the box to the kegs or markers 200 feet away, rides through two kegs or markers, circling the center one and returning to the box. The rider must stop within the square of four kegs or markers.
3. There will be a 5-second penalty for each keg or marker knocked over.
4. Spinning to a stop more than 90 degrees in the box, as determined by the judge, will result in disqualification.

Disqualifications—Causes of disqualification include:

- Stepping over the line of the box at the end of the pattern.
- Not stopping forward motion in the box.
- Spinning to a stop (see #4 in the previous list).

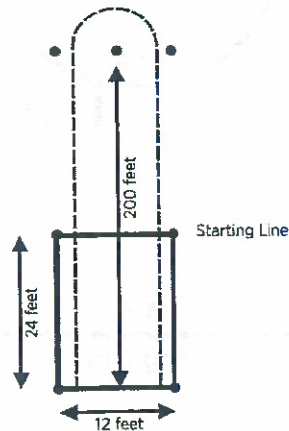

Van Buren Youth Fair

KEYHOLE RACE

Class #497, #498, #499, #500, #501

Show Date: July 15, 2024

The course will be laid out with a limed keyhole on the ground with the opening of the keyhole facing the starting line (see fig. 24). The center of the circle should be 100 feet from the timing line. The keyhole will be in the form of a broken circle 22 feet in diameter with a throat 5 feet wide. The angled sides are 5 feet long. The horse will cross the timing line, enter the circle of the keyhole, turn around (in either direction) entirely within the circle of the keyhole, and re-cross the timing line.

Disqualification—Causes of disqualification include:

- The horse stepping on or over the chalk line at any point.
- The horse turning around in the throat of the keyhole rather than in the circle.
- Failing to complete the pattern.
- Failing to start or finish between the two markers.

PATTERN 2

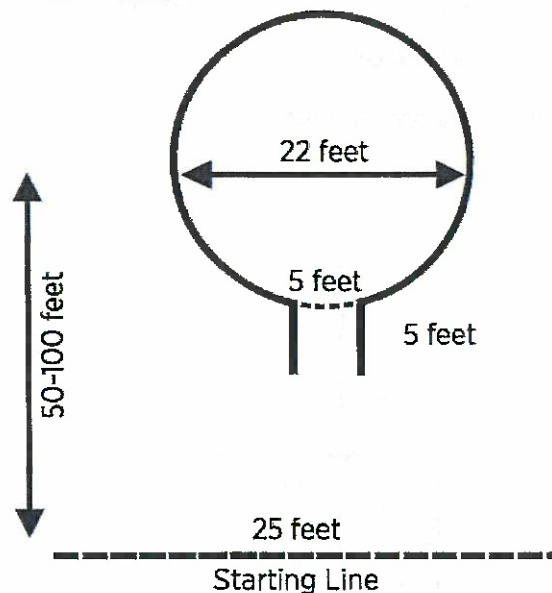

Van Buren Fair
English Showmanship (Pee Wee)

Class Number: 502

Show Date: July 16, 2024

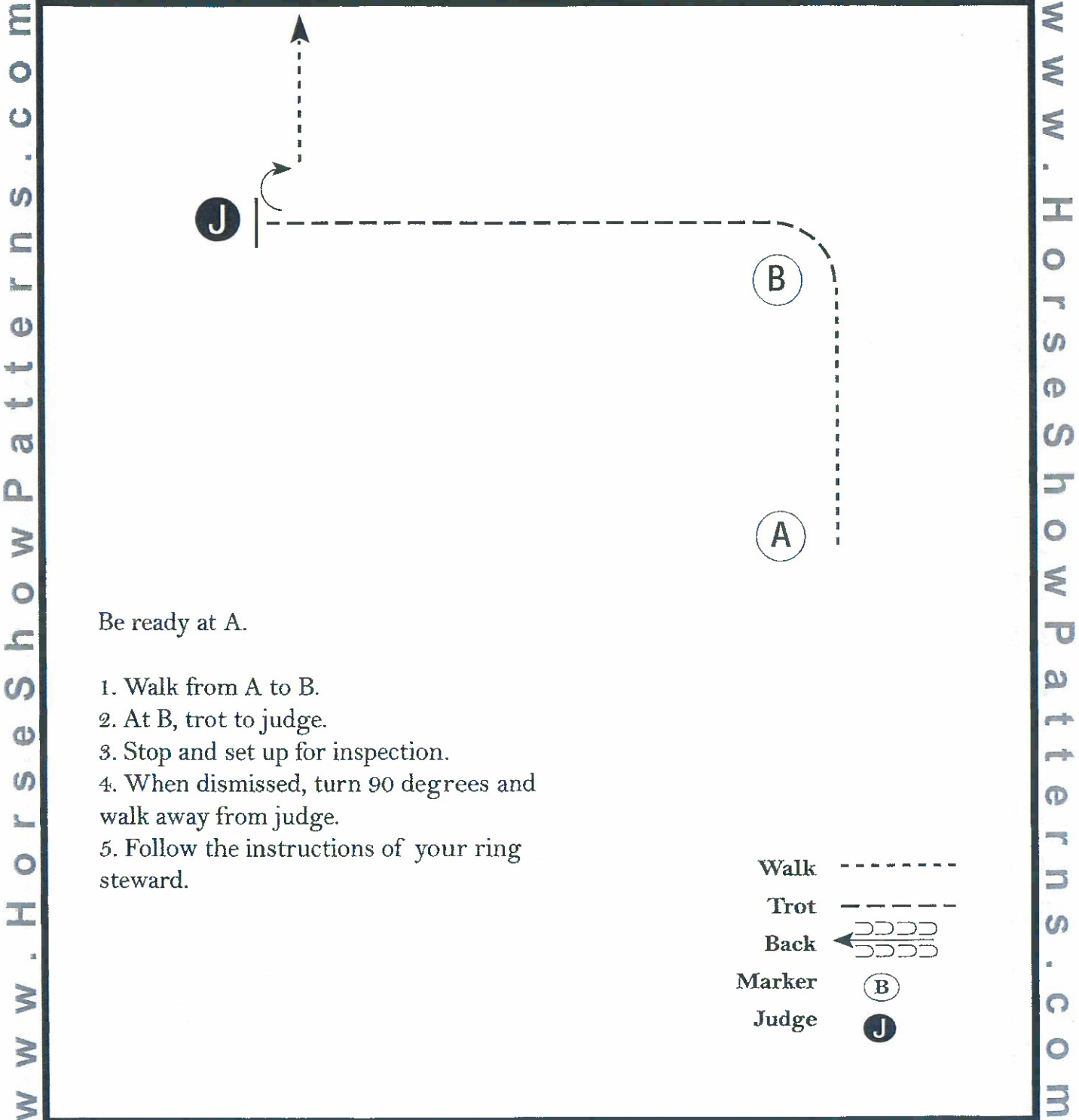

[SWT-11]

Pattern Provided by:
Show Committee

Van Buren Fair
English Showmanship (Junior & Senior)

Class Number: 503, 504

Show Date: July 16, 2024

www.HorseShowPatterns.com

www.HorseShowPatterns.com

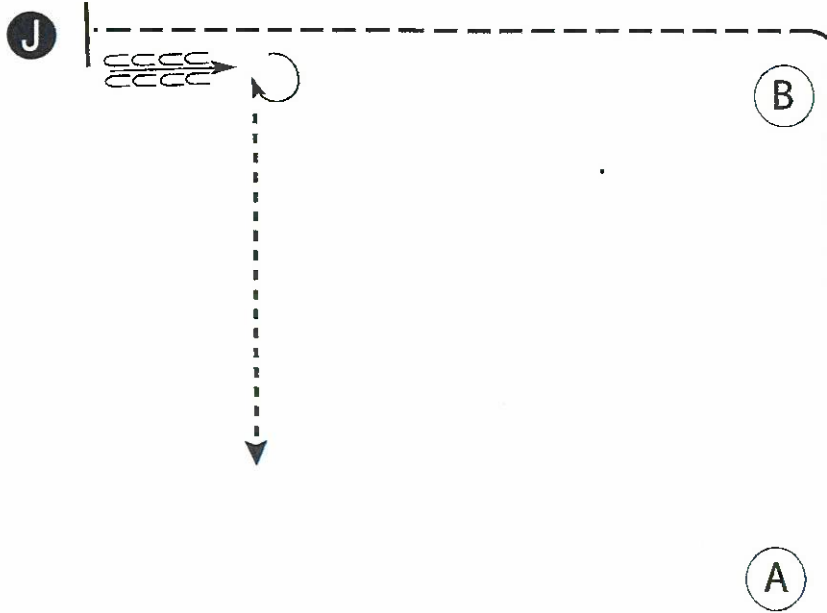

Be ready at A.

1. Walk to B.
2. Trot around B and to judge.
3. Stop and set up for inspection.
4. When dismissed, back one horse length.
5. Turn 270 degrees and walk straight off.

Walk	-----
Trot	- - - - -
Back	← 〰〰〰〰
Marker	⊙ B
Judge	● J

[S/1-23]

Pattern Provided by:
Show Committee

Van Buren Youth Fair

In Hand Jumping

Show Date: Tuesday, July 16, 2024

Class No: 505

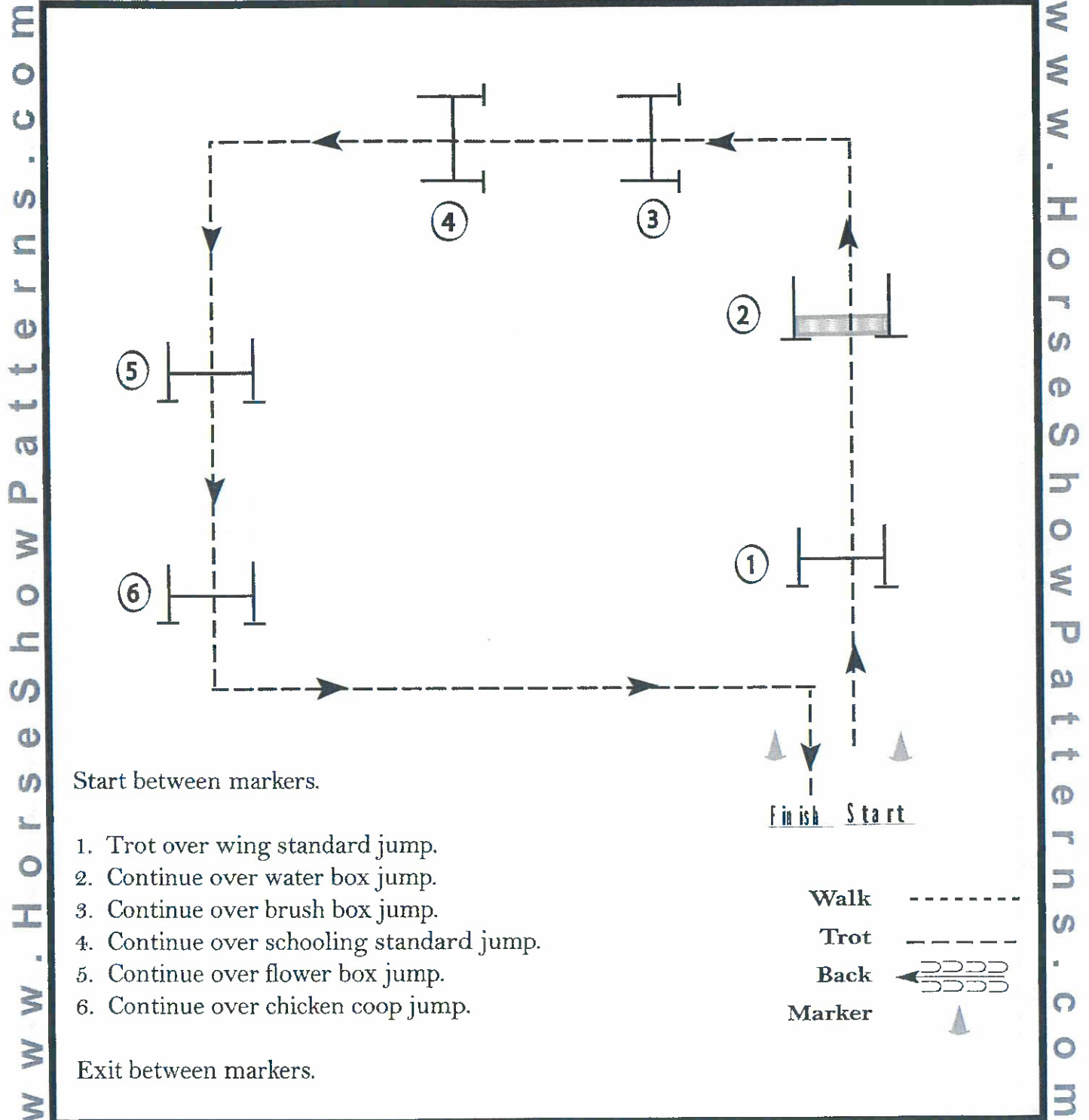

[MHP/H-1]

Pattern Provided by: Van Buren County Horse Committee

Van Buren Youth Fair

Equitation Over Fences & Jumping

Hunter Over Fences

Show Date: Tuesday, July 16, 2024

Class No: 506 & 507

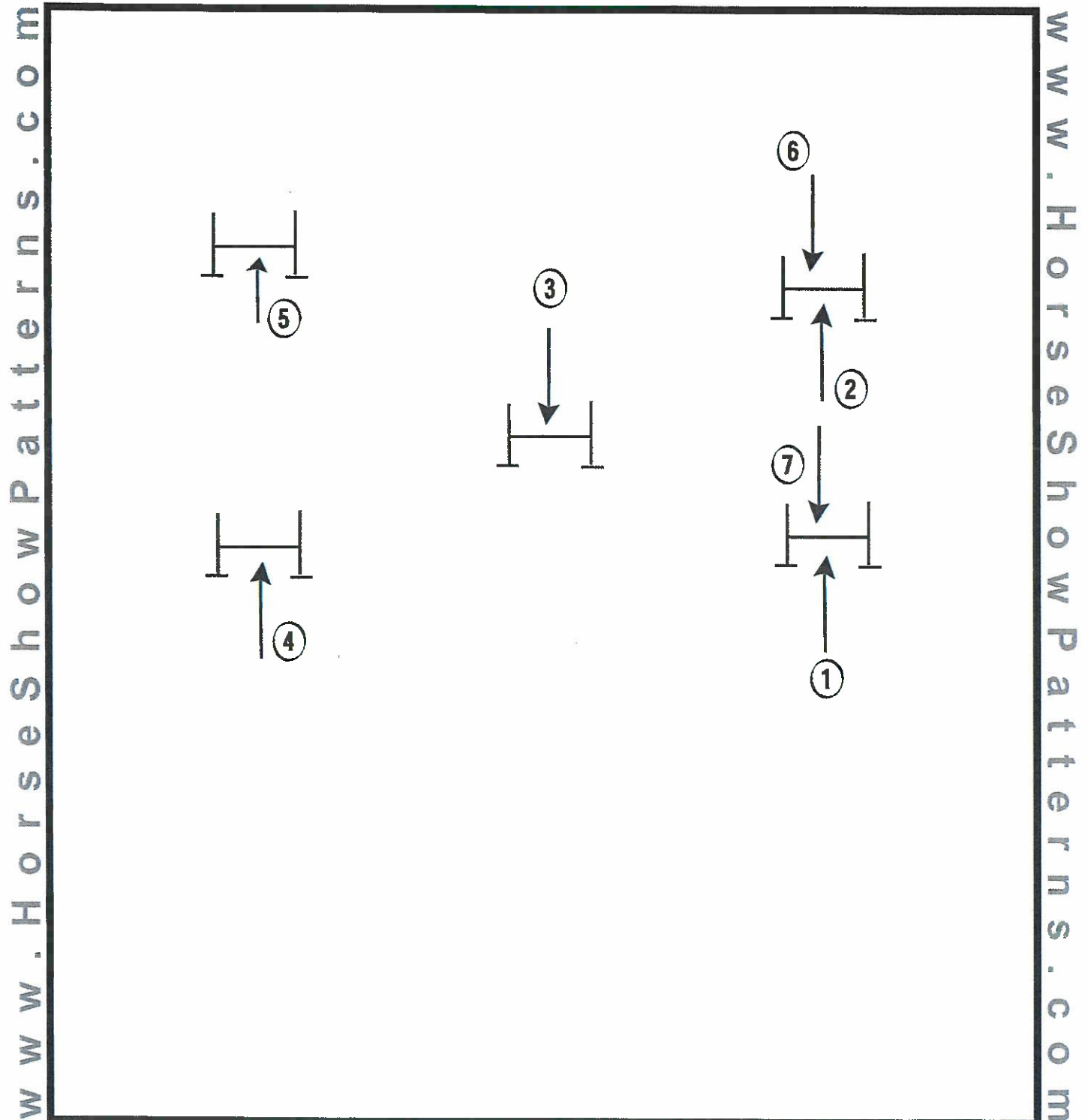

[MHP/H-8]

Pattern Provided by: Van Buren County Horse Committee

Van Buren Fair
English Equitation (Pee Wee / Walk -Trot)

Class Number: 509, 510

Show Date: July 16, 2024

www.HorseShowPatterns.com

www.HorseShowPatterns.com

Be ready at A.

1. Walk from A to B.
2. At B, perform a posting trot circle to the right on the proper diagonal.
3. Return to B and perform a sitting trot to C.
4. Stop at C and back approximately one horse length.

Follow the instructions of your ring steward.

Walk	-----
Trot	- - - - -
Extended Trot	- - - - -
Canter	—————
Leg Yield	
Lead Change	↘ ↙
Back	⊖ ⊖ ⊖
Marker	Ⓚ
Sidepass	← ←
Hand Gallop	-----

[HSE/WT-32]

Pattern Provided by:
Show Committee

Van Buren Fair
Pony & JR English Equitation

Class Number: 511, 513

Show Date: July 16, 2024

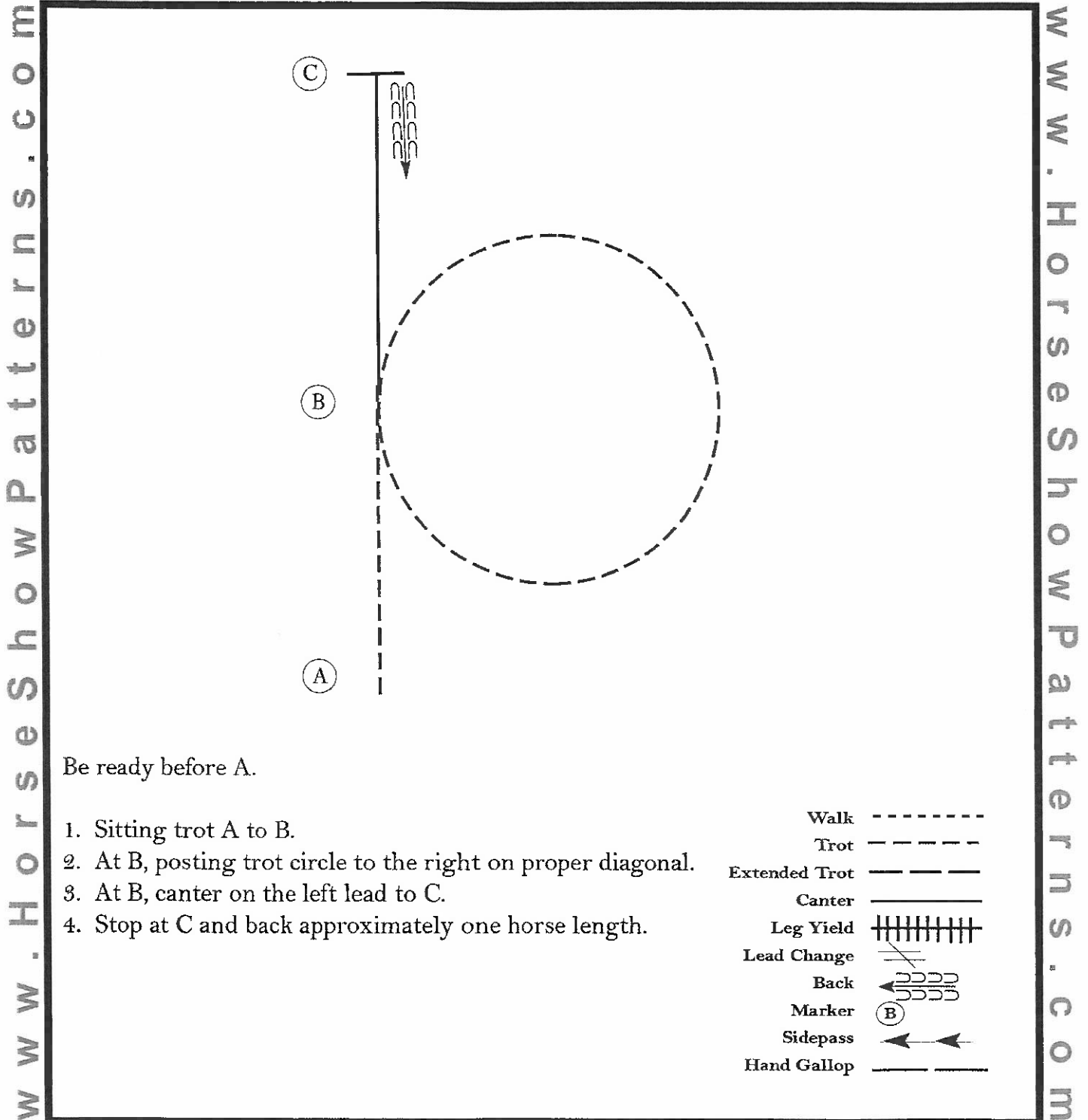

Be ready before A.

1. Sitting trot A to B.
2. At B, posting trot circle to the right on proper diagonal.
3. At B, canter on the left lead to C.
4. Stop at C and back approximately one horse length.

Walk
Trot	-----
Extended Trot	————
Canter	————
Leg Yield	
Lead Change	—/—
Back	←←←←
Marker	ⓑ
Sidepass	←←
Hand Gallop	-----

[HSE/1-2]

Pattern Provided by:
Show Committee

Van Buren Fair
SR English Equitation & JR Championship)

Class Number: 515, 516

Show Date: July 16, 2024

www.HorseShowPatterns.com

www.HorseShowPatterns.com

Be ready before A.

1. Walk to A.
2. Sitting trot from A to B.
3. At B, canter a circle to the right on the right lead.
4. At B, posting trot on the right diagonal to C.
5. Stop at C and back approximately one horse length.

Follow the instructions of your ring steward.

Walk	-----
Trot	-----
Extended Trot	-----
Canter	-----
Leg Yield	
Lead Change	↙ ↘
Back	← ← ← ← ← ← ← ← ← ←
Marker	(B)
Sidepass	← →
Hand Gallop	-----

[HSE/1-32]

Pattern Provided by:
Show Committee

Van Buren Fair

English Equitation (Senior Equitation Championship)

Class Number: 517

Show Date: July 16, 2024

www.HorseShowPatterns.com

www.HorseShowPatterns.com

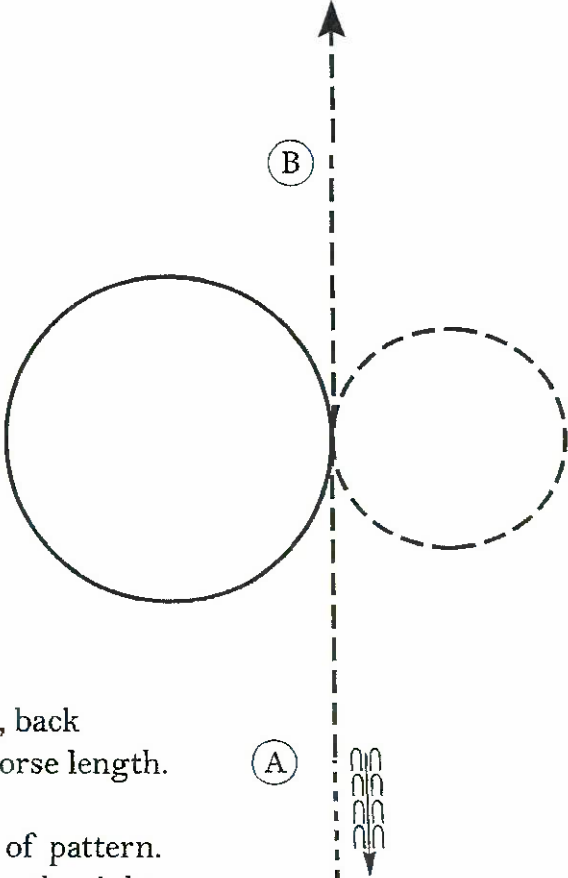

Be ready at A.

1. When acknowledged, back approximately one horse length.
2. Walk to A.
3. Sitting trot to center of pattern.
4. Posting trot a circle to the right.
5. Canter a larger circle to the left.
6. Posting trot on the right diagonal straight away from B.

Pattern is over once you have trotted past B more than 2 horse lengths.

Follow the instructions of your ring steward.

Walk	-----
Trot	- - - - -
Extended Trot	—————
Canter	—————
Leg Yield	
Lead Change	—/—
Back	←←←←←
Marker	⊙
Sidepass	←←←←←
Hand Gallop	—————

[HSE/1-55]

Pattern Provided by:
Show Committee



Van Buren Youth Fair
Class #527
 Show Day: July 16, 2024



2023 USEF TRAINING LEVEL TEST 1

INTRODUCE	ENTRY NO: _____
Working trot; working canter; medium walk; free walk; 20m circles in trot and canter	Conditions: ARENA SIZE: Standard or Small AVERAGE RIDE TIME: 5:00 (Std.) or 4:00 (Small) (from entry at A to final halt) <i>Suggested to add at least 2 min. for scheduling purposes</i>
	MAXIMUM PTS: 260

PURPOSE

To confirm that the horse demonstrates correct basics, by showing suppleness both laterally and longitudinally, moving freely forward in a clear rhythm with a steady tempo, and readily accepting contact with the bit. Correct geometry and lines of travel should be shown.

All trot work may be ridden sitting or rising, unless otherwise stated.
 Halts may be through the walk.

READER PLEASE NOTE: Anything in parentheses should not be read.

	TEST	DIRECTIVES	POINTS	COEF	TOTAL	REMARKS
1.	A X	Enter working trot Halt, salute Proceed working trot	Regularity and quality of trot; willing, calm transitions; straightness; attentiveness; immobility (min. 3 seconds)			
2.	C E	Track left Circle left 20m	Regularity and quality of trot; shape and size of circle; bend; balance	2		
3.	A	Circle left 20m developing left lead canter in first quarter of circle	Willing, calm transition; regularity and quality of gaits; shape and size of circle; bend; balance			
4.	A-F-B	Working canter	Regularity and quality of canter; bend and balance in corner; straightness			
5.	Between B & M	Working trot	Willing, calm transition; regularity and quality of gaits; straightness; bend and balance in corner	2		
6.	Between C & H	Medium walk	Willing, calm transition; regularity, quality, bend and balance in corner	2		
7.	E-F F	Change rein, free walk Medium walk	Regularity and quality of walks; reach, overtrack, and ground cover of free walk allowing complete freedom to stretch the neck forward and downward; straightness; willing, calm transitions	2		
8.	A	Working trot	Willing, calm transition; regularity and quality of trot; bend and balance in corner; straightness			
9.	E	Circle right 20m	Regularity and quality of trot; shape and size of circle; bend; balance	2		
10.	C	Circle right 20m developing right lead canter in first quarter of circle	Willing, calm transition; regularity and quality of gaits; shape and size of circle; bend; balance			
11.	C-M-B	Working canter	Regularity and quality of canter; bend and balance in corner; straightness			
12.	Between B & F	Working trot	Willing, calm transition; regularity and quality of gaits; straightness; bend and balance in corner	2		
13.	A X	Down centerline Halt, salute	Bend and balance in turn; regularity and quality of trot; willing, calm transition; straightness; attentiveness; immobility (min. 3 seconds)			

Leave arena at A in free walk.



2023 USEF TRAINING LEVEL TEST 1



COLLECTIVE MARKS			
GAITS (Freedom and regularity)		1	
IMPULSION (Desire to move forward; elasticity of the steps; suppleness of the back; engagement of the hindquarters)		2	
SUBMISSION (Willing cooperation; harmony; attention and confidence; acceptance of bit and aids; straightness; lightness of forehand and ease of movements)		2	
RIDER'S POSITION AND SEAT (Alignment; posture; stability; weight placement; following mechanics of the gaits)		1	
RIDER'S CORRECT AND EFFECTIVE USE OF AIDS (Clarity; subtlety; independence; accuracy of test)		1	
FURTHER REMARKS:			
		SUBTOTAL:	
To be deducted Errors of the course and omissions are penalized		ERRORS: (-)	
		TOTAL POINTS: (Max Points: 260)	
		1st Time = 2 points 2nd Time = 4 points 3rd Time = Elimination	

United States Equestrian Federation, Inc. 2023 USEF TRAINING LEVEL TEST 1	
_____	Name of Competition
_____	Date of Competition
_____	Name and Number of Horse
_____	Name of Rider
Final Score Maximum Pts: 260	
_____	Points
_____	Percent
_____	Name of Judge
_____	Signature of Judge

Score Sheet effective date: December 1, 2022 - November 30, 2026



Van Buren Youth Fair
 Class #528
 Show Day: July 16, 2024



2023 USEF TRAINING LEVEL TEST 3

PURPOSE

To confirm that the horse demonstrates correct basics, by showing suppleness both laterally and longitudinally, moving freely forward in a clear rhythm with a steady tempo, and readily accepting contact with the bit. Correct geometry and lines of travel should be shown.

All trot work may be ridden sitting or rising, unless otherwise stated. Halts may be through the walk.

READER PLEASE NOTE: Anything in parentheses should not be read.

INTRODUCE	ENTRY NO:
Changing of bend on a shallow loop, canter-trot transition on diagonal	<p>Conditions:</p> <p>ARENA SIZE: Standard or Small AVERAGE RIDE TIME: 5:30 (Std.) or 4:30 (Small) (from entry at A to final halt) <i>Suggested to add at least 2 min. for scheduling purposes</i></p>
	MAXIMUM PTS: 250

		TEST	DIRECTIVES	POINTS	COEF	TOTAL	REMARKS
1.	A X	Enter working trot Halt, salute Proceed working trot	Regularity and quality of trot; willing, calm transitions; straightness; attentiveness; immobility (min. 3 seconds)				
2.	C H-X-K	Track left Slightly after H begin a single loop to X returning to the track slightly before K	Regularity and quality of trot; bend and balance in turns; shape and size of loop; changes of bend; balance		2		
3.	Between A & F	Working canter left lead	Willing, calm transition; regularity and quality of gaits; bend in corner; straightness				
4.	B	Circle left 20m	Regularity and quality of canter; shape and size of circle; bend; balance				
5.	H-X-F X	Change rein Working trot	Regularity and quality of gaits; willing, calm transition; straightness; bend in corner				
6.	A	Medium walk	Willing, calm transition; regularity, quality		2		
7.	K-X-H H	Free walk Medium walk	Regularity and quality of walks; reach, overtrack, and ground cover of free walk allowing complete freedom to stretch the neck forward and downward; straightness; willing, calm transitions		2		
8.	C M-X-F	Working Trot Slightly after M begin a single loop to X returning to the track slightly before F	Regularity and quality of trot; shape and size of loop; changes of bend and balance		2		
9.	Between A & K	Working canter right lead	Willing, calm transition; regularity and quality of gaits; bend and balance in corner; straightness				
10.	E	Circle right 20m	Regularity and quality of canter; shape and size of circle; bend; balance				
11.	C	Working trot	Willing, calm transition; regularity and quality of trot				
12.	B Before B B	Circle right 20m in rising trot allowing the horse to stretch forward and downward Shorten the reins Working trot	Forward and downward stretch over the back into a light contact, maintaining balance and quality of trot; bend; shape and size of circle; willing, calm transitions		2		
13.	A X	Down centerline Halt, salute	Bend and balance in turn; regularity and quality of trot; willing, calm transition; straight, attentive halt; immobile (min. 3 seconds)				

Leave arena at A in free walk.



2023 USEF TRAINING LEVEL TEST 3

COLLECTIVE MARKS			
GAITS (Freedom and regularity)		1	
IMPULSION (Desire to move forward; elasticity of the steps; suppleness of the back; engagement of the hindquarters)		2	
SUBMISSION (Willing cooperation; harmony; attention and confidence; acceptance of bit and aids; straightness; lightness of forehand and ease of movements)		2	
RIDER'S POSITION AND SEAT (Alignment; posture; stability; weight placement; following mechanics of the gaits)		1	
RIDER'S CORRECT AND EFFECTIVE USE OF AIDS (Clarity; subtlety; independence; accuracy of test)		1	
FURTHER REMARKS:			
<p>To be deducted Errors of the course and omissions are penalized</p> <p>1st Time = 2 points 2nd Time = 4 points 3rd Time = Elimination</p>		 <p>Movements #2 and #8</p>	<p>SUBTOTAL:</p> <p>ERRORS: (-)</p> <p>TOTAL POINTS: (Max Points: 250)</p>

United States Equestrian Federation, Inc. 2023 USEF TRAINING LEVEL TEST 3	
_____	Name of Competition
_____	Date of Competition
_____	Name and Number of Horse
_____	Name of Rider
Final Score Maximum Pts: 250	
_____	Points
_____	Percent
_____	Name of Judge
_____	Signature of Judge

Score Sheet effective date: December 1, 2022 – November 30, 2026



Van Buren Youth Fair
 Class # 529 Show Day: July 16, 2024
WDA A 2022 WESTERN DRESSAGE BASIC LEVEL TEST 3
 WESTERN DRESSAGE ASSOCIATION® OF AMERICA

PURPOSE
 Tests confirm that the horse is supple and moves freely forward in a clear and steady rhythm, accepting light contact with the bit. The horse demonstrates a greater understanding of the aids and calm acceptance of the bridle; greater emphasis is placed on relaxation, willing cooperation, harmony, rideability and pure gaits. The horse is beginning to develop more impulsion and balance.

NEW REQUIREMENTS
 Half circle 10 meters returning to the track at working jog

ENTRY NO: _____

ARENA SIZE:
 Small (40m x 20m) or Large (60m x 20m)
AVERAGE RIDE TIME:
 4:00 (Small) or 5:00 (Large)

MAXIMUM PTS: 230

*COEFFICIENT

All jog work may be ridden sitting or rising.

		TEST	DIRECTIVES	POINTS	TOTAL	REMARKS
1	A X	Enter working jog Halt through the walk, salute Proceed working jog	Straightness; regularity and quality of the jog and walk; straight, balanced, immobile halt with prompt, smooth transition to jog.			
2	C E - X	Track left Half circle left 10m returning to the track at H	Balance and bend in the turn and corner; straightness; balance and inside bend on the half circle; regularity and quality of the jog.			
3	Between H & C	Develop working lope, right lead	Willing, smooth transition; regularity and quality of the lope.			
4	C	Circle right 20m, working lope	Size and shape of circle with inside bend; regularity and quality of the lope.			
5	Between C & M	Develop working jog	Smooth transition; straightness; regularity and quality of the lope and jog.			
6	B - X	Half circle right 10m returning to the track at M	Balance and inside bend on the half circle; straightness; balance and bend in the corner; regularity and quality of jog.			
7	C Before C	Circle left 20m, free jog Gather the reins, working jog	Stretch forward and down over the topline; moderate lengthening of stride and frame; maintaining balance and tempo; smooth, willing release and retake of the reins; size and shape of circle with inside bend; regularity of the jogs.	2		
8	Between C & H	Develop working walk	Willing, smooth transition; regularity and quality of the walk.			
9	H - X - F F	Free walk Working walk	Horse willing to freely stretch the neck forward and down; relaxation; swing through the back; ground cover; straightness; willing, smooth transition; balance and bend in the corner; regularity and quality of the walks.	2		
10	Between A & K E - X	Develop working jog Half circle right 10m returning to the track at K	Willing, smooth transition; balance and inside bend on the half circle; straightness; regularity and quality of the jog.			
11	Between K & A	Develop working lope, left lead	Willing, smooth transition; regularity and quality of the lope.			
12	A	Circle left 20m, working lope	Size and shape of circle with inside bend; regularity and quality of the lope.			
13	Between A & F	Develop working jog	Smooth transition; straightness; regularity and quality of the lope and jog.			
14	B - X	Half circle left 10m returning to the track at F	Balance and inside bend on the half circle; straightness; balance and bend in the corner; regularity and quality of jog.			
15	A X	Down centerline Halt through the walk, salute	Balance and bend in the turn; straightness; regularity and quality of the jog and walk; balance in downward transition to square, straight halt, immobility.			

Leave arena at A in a walk with looped or long reins.



WDAA 2022 WESTERN DRESSAGE BASIC LEVEL TEST 3
 WESTERN DRESSAGE ASSOCIATION® OF AMERICA

*COEFFICIENT

COLLECTIVE MARKS	POINTS	*	TOTAL	REMARKS
GAITS: freedom and regularity.		1		
IMPULSION: desire to move forward with suppleness of the back and steady tempo		1		
RIDER'S POSITION, SEAT AND HANDS: well-balanced elastic seat demonstrating vertical, centered alignment, with light independent contact from hand(s)		1		
RIDER'S CORRECT AND EFFECTIVE USE OF THE AIDS: evidenced by the horse's responsiveness; steady elastic connection cultivating athletic expression. Accuracy - precise placement of the figures and transitions, the effectiveness of the rider's aids determines the accurate fulfillment of the required movements of the tests		1		
HARMONY: The horse accepts the aids and influence of the rider with attention, relaxation and confidence; and demonstrates a willing partnership between horse and rider resulting in a free-flowing performance.		2		
SUBTOTAL:	total of points and coefficients above			
ERRORS:	subtract from subtotal			
TOTAL POINTS:	subtotal minus any errors			
REMARKS:				

Attention competitors submitting points to WDAA for the Horse Lifetime Points & Awards Program: Only the bottom portion below needs to be submitted along with the Test/Rail Submission Form to verify your points. Please go to www.westerndressageassociation.org for more information.

WDAA 2022 BASIC LEVEL TEST 3

Name of Competition

Date of Competition

Name and Number of Horse

Name of Rider

Final Score
 Maximum Points: 230

Points / Percent

Name of Judge

Signature of Judge

Van Buren Fair
Western Showmanship (In Hand, Leadline, HRH, Pee Wee)

Class Number: 530, 531, 532, 533

Show Date: July 17, 2024

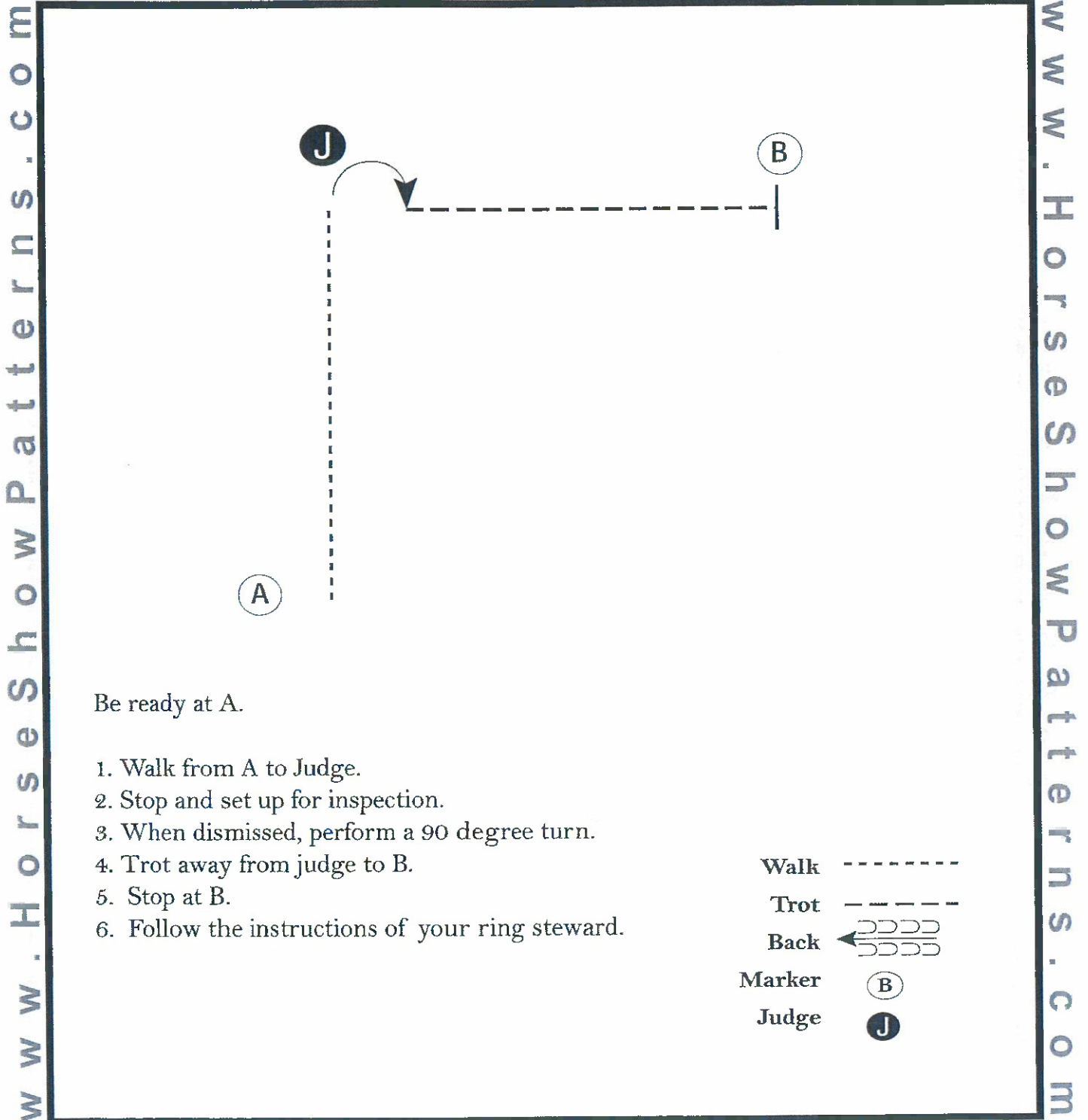

[SWT-7]

Pattern Provided by:
Show Committee

Van Buren Fair

Western Showmanship (Walk-Trot & Pony)

Class Number: 534 and 535

Show Date: July 17, 2024

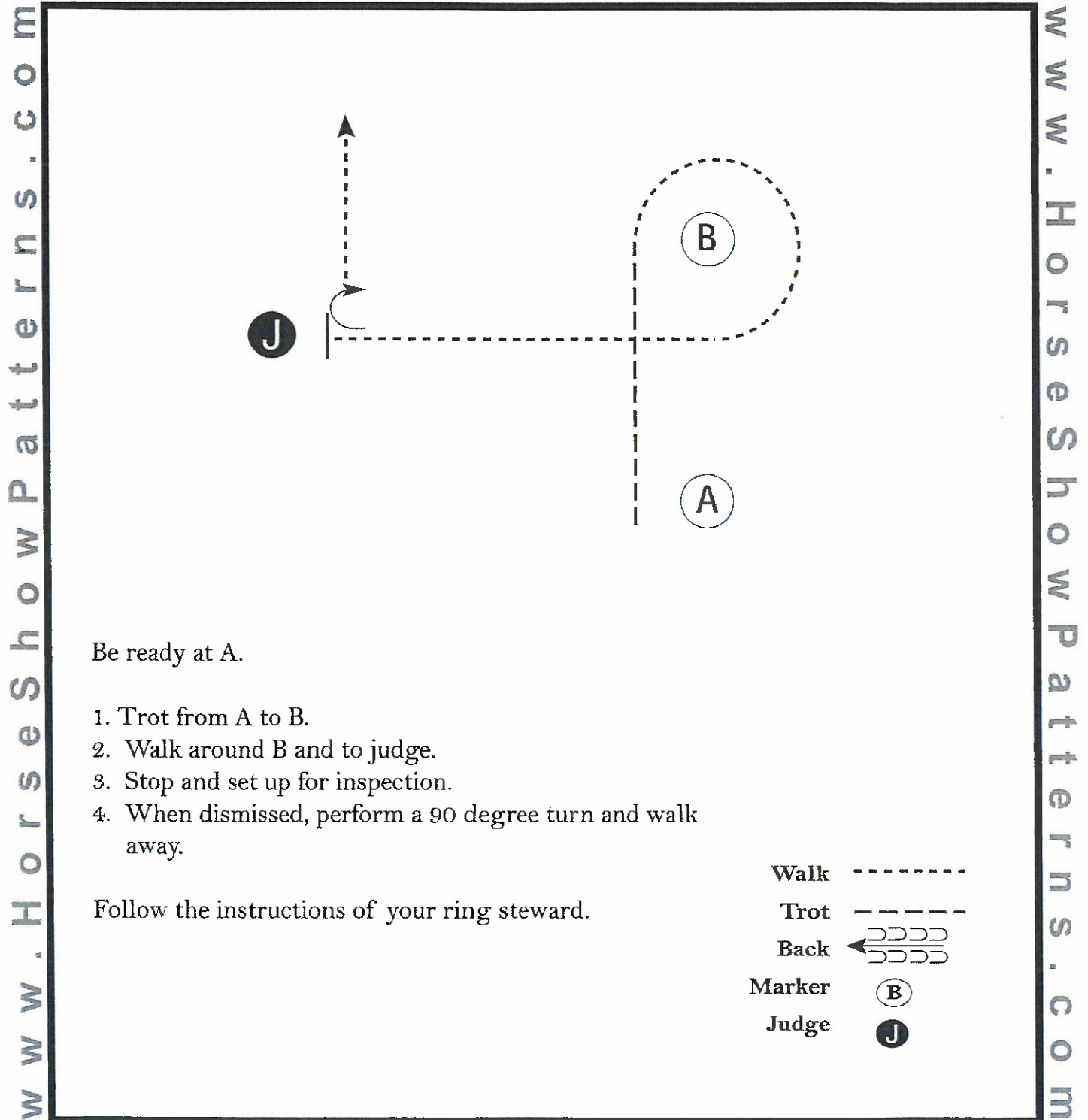

[S/WT-55]

Pattern Provided by:
Show Committee

Van Buren Fair

JR, Gymkhana Western Showmanship & SR Championship

Class Number: 537, 540, 542

Show Date: July 17, 2024

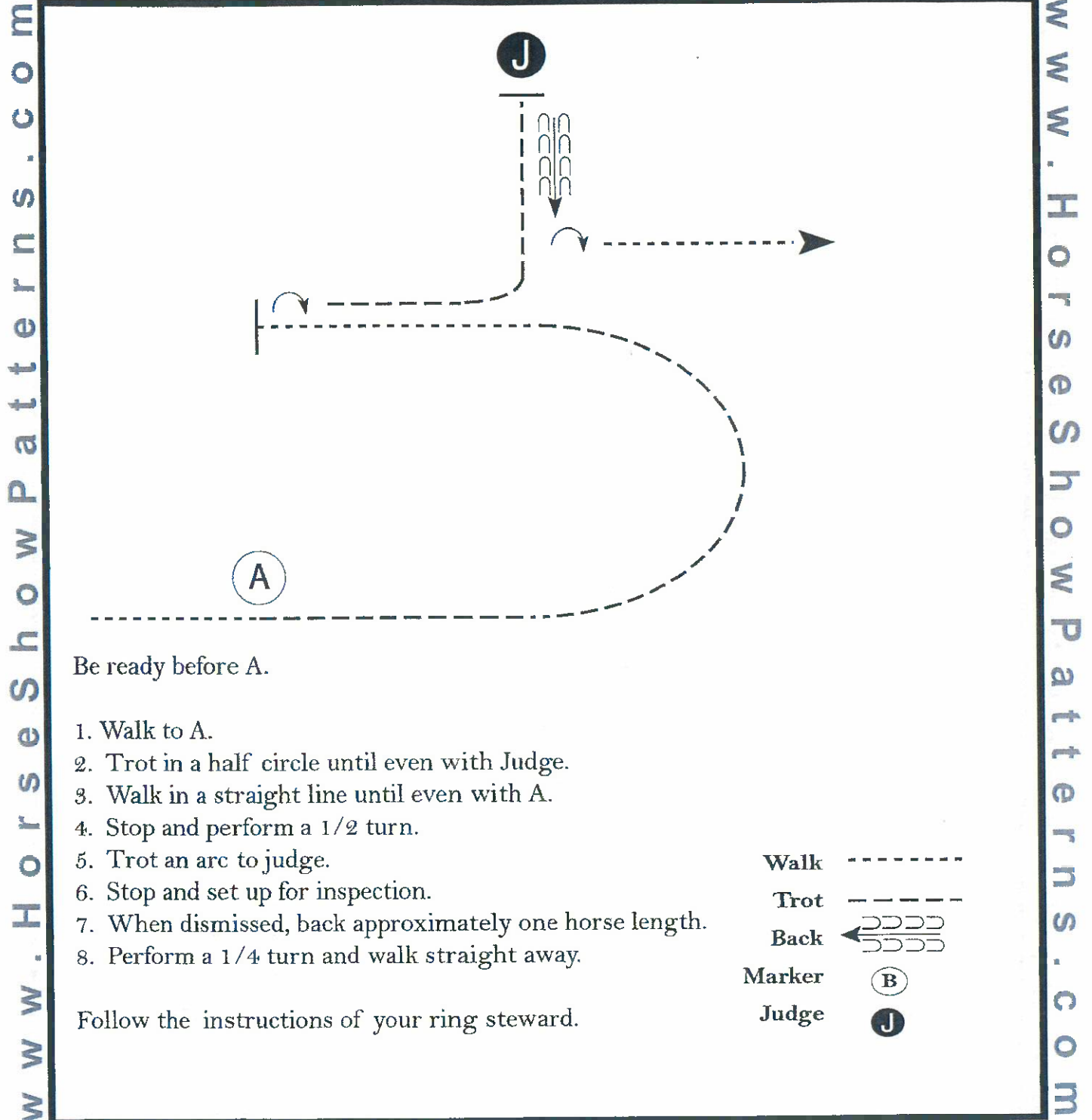

[S/2-83]

Pattern Provided by:
Show Committee

Van Buren Fair
SR Western Showmanship & JR Championship

Class Number: 539 & 541

Show Date: July 17, 2024

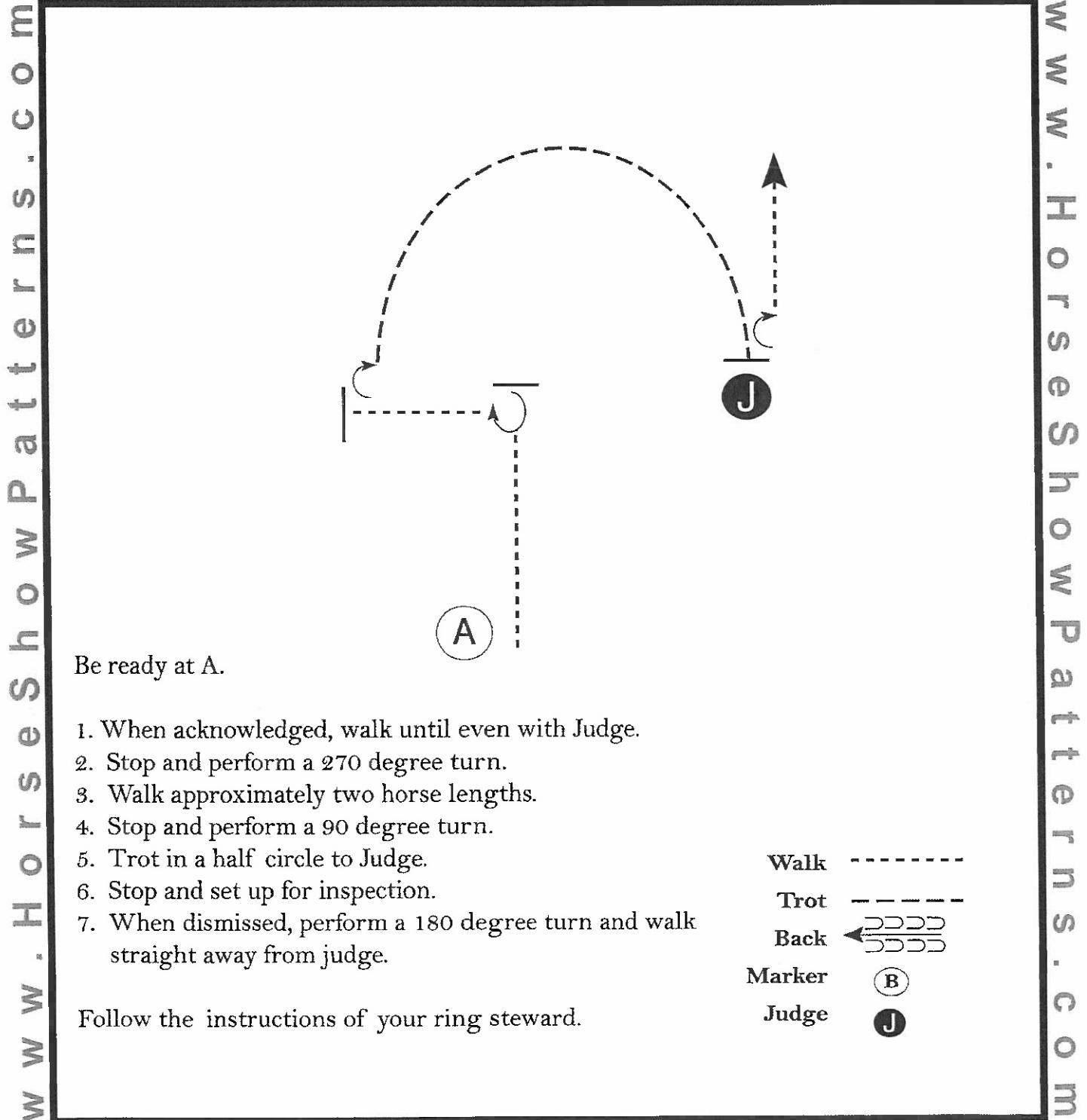

Be ready at A.

1. When acknowledged, walk until even with Judge.
2. Stop and perform a 270 degree turn.
3. Walk approximately two horse lengths.
4. Stop and perform a 90 degree turn.
5. Trot in a half circle to Judge.
6. Stop and set up for inspection.
7. When dismissed, perform a 180 degree turn and walk straight away from judge.

Follow the instructions of your ring steward.

Walk	-----
Trot	- - - - -
Back	←=====
Marker	ⓑ
Judge	ⓐ

[S/1-68]

Pattern Provided by:
Show Committee

Van Buren Fair
Lead-line and HRH Horsemanship

Class Number: 543, 544

Show Date: July 17, 2024

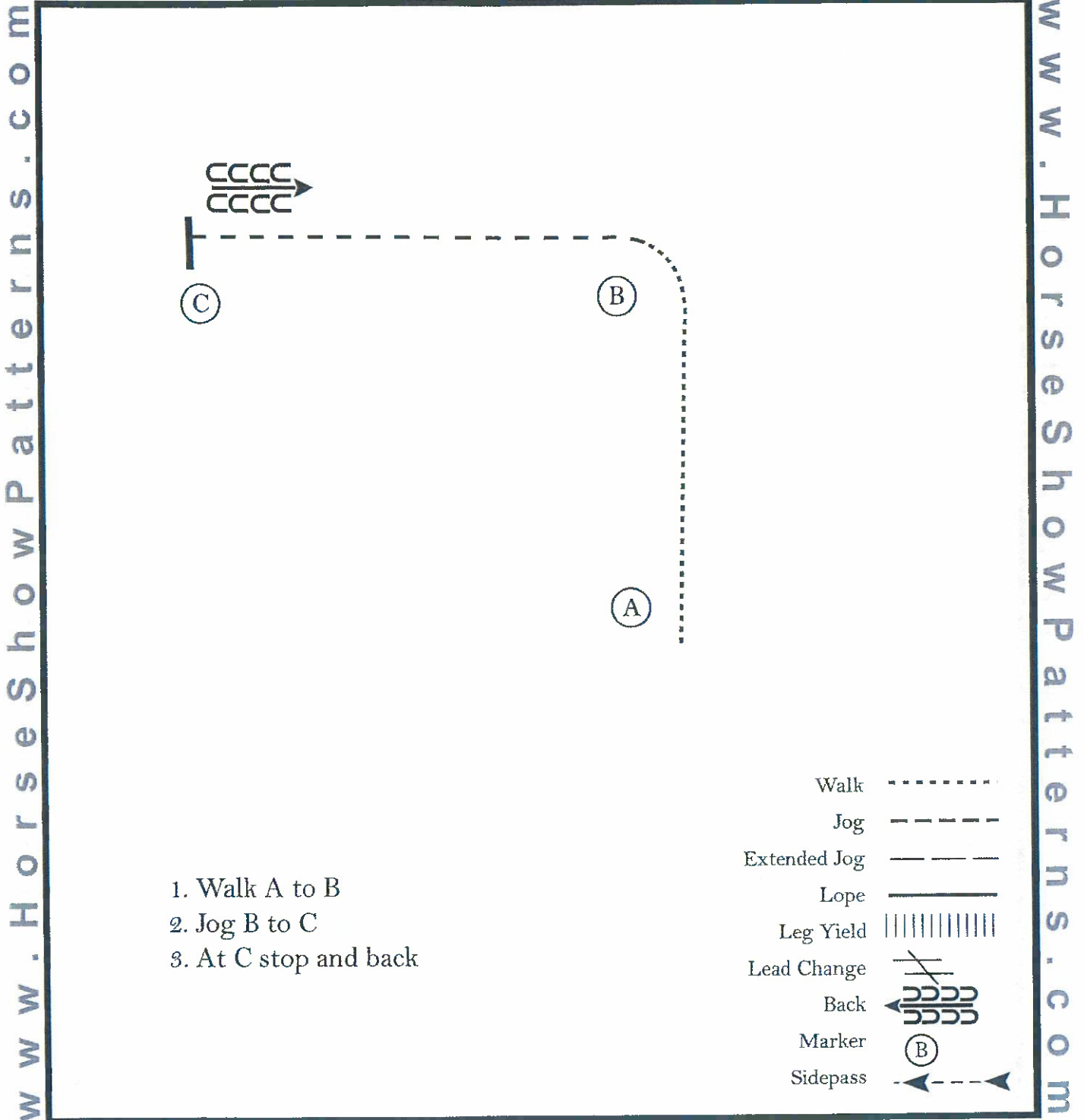

1. Walk A to B
2. Jog B to C
3. At C stop and back

[WH/WT-4]

Pattern Provided by:

Van Buren Fair

Western Horsemanship (Pee Wee/Walk Trot)

Class Number: 545, 546

Show Date: July 17, 2024

w w w . H o r s e S h o w P a t t e r n s . c o m

w w w . H o r s e S h o w P a t t e r n s . c o m

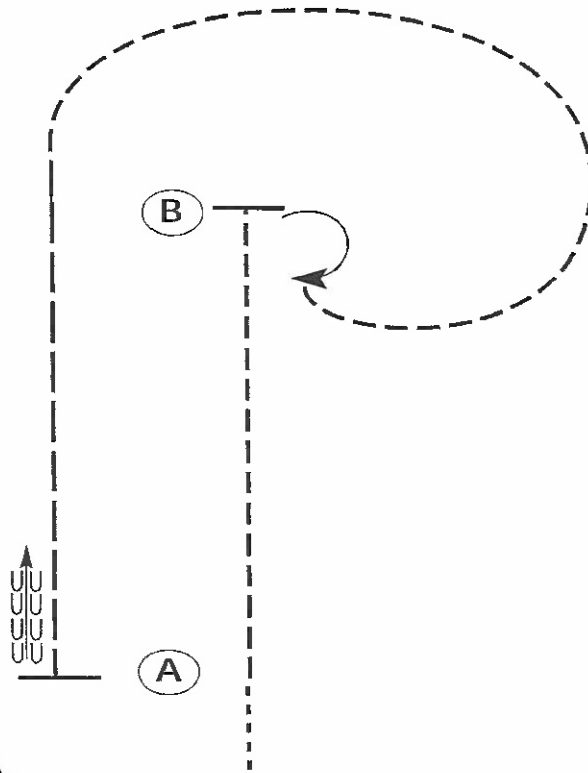

Be ready before A.

1. Walk to A.
2. Jog to B.
3. Turn 180 degrees to the right.
4. Jog back around to B.
5. Extend the jog from B to A.
6. Stop at A and back approximately one horse length.

Follow the instructions of your ring steward.

Walk	-----
Jog	- - - - -
Extended Jog	- - - - -
Lope	—————
Leg Yield	
Lead Change	↘
Back	←←←←←
Marker	⊙ B
Sidepass	←←←←←

[WH/WT-44]

Pattern Provided by:
Show Committee

Van Buren Fair
Western Horsemanship (Pony/Junior/Gymkhana)

Class Number: 551, 553, 556

Show Date: July 17, 2024

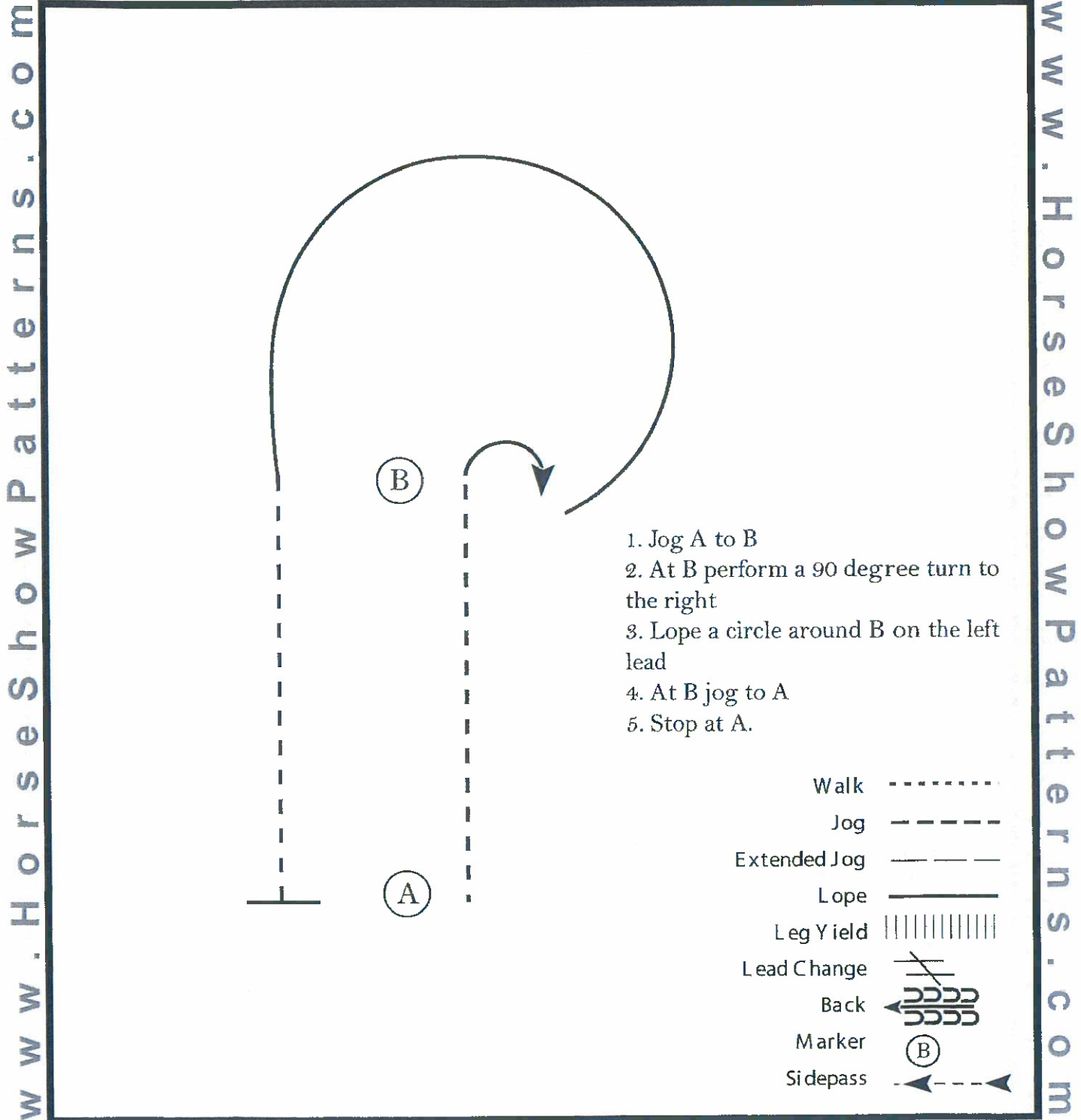

1. Jog A to B
2. At B perform a 90 degree turn to the right
3. Lope a circle around B on the left lead
4. At B jog to A
5. Stop at A.

Walk
Jog	- - - - -
Extended Jog	— — — — —
Lope	—————
Leg Yield	
Lead Change	↗ ↘
Back	← ← ← ← ←
Marker	⊙
Sidepass	← — — — — →

[WH/1-14]

Pattern Provided by:
Show Committee

Van Buren Fair

Sr. Western Horsemanship & JR Championship

Class Number: 555, 557

Show Date: July 17, 2024

W W W . H O R S E S H O W P A T T E R N S . C O M

W W W . H O R S E S H O W P A T T E R N S . C O M

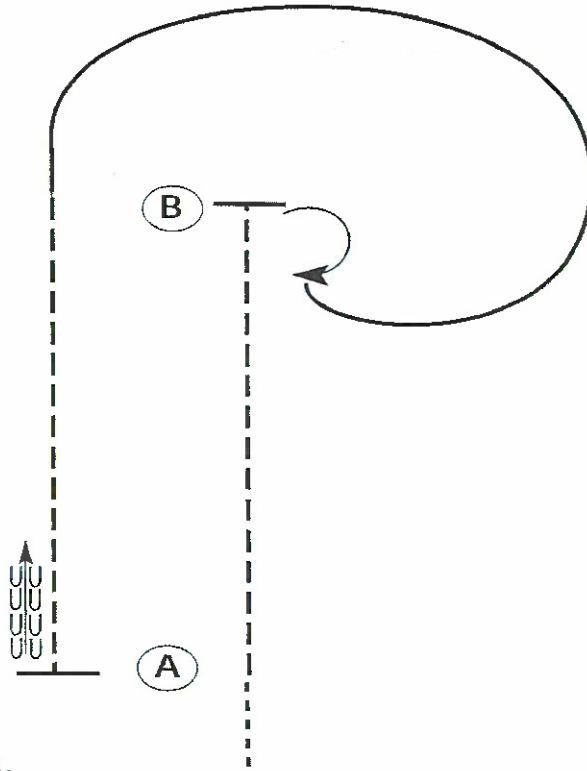

Be ready before A.

1. Walk to A.
2. Jog to B.
3. Turn 180 degrees to the right.
4. Lope on the left lead back around to B.
5. Jog from B to A.
6. Stop at A and back approximately one horse length.

Follow the instructions of your ring steward.

Walk	-----
Jog	- - - - -
Extended Jog	— — — — —
Lope	—————
Leg Yield	
Lead Change	↘
Back	←←←←←
Marker	⊙ B
Sidepass	←←←←←

[WH/1-44]

Pattern Provided by:
Show Committee

Van Buren Fair
Western Horsemanship (Senior Championship)

Class Number: 558

Show Date: July 17, 2024

www.HorseShowPatterns.com
www.HorseShowPatterns.com

Be ready at A.

1. Walk from A 1/2 way to B.
2. Jog the rest of the way to B.
3. Lope a circle to the right.
4. Perform an extended jog from B to C.
5. Stop at C and back one horse length.

Retire to the rail or line up at a jog.

Walk	-----
Jog	- - - - -
Extended Jog	- - - - -
Lope	—————
Leg Yield	
Lead Change	/ \
Back	← ← ← ← ←
Marker	(B)
Sidepass	← ← ← ← ←

[WH/1-25]

Pattern Provided by:
Show Committee

Van Buren Youth Fair

POLE BENDING

Class #567, #568, #569, #570, #571, #572

Show Date: July 18, 2024

The pole bending pattern (see fig. 25) is run around six poles. The poles are placed in a straight line 21 feet apart, going away from the starting line. The first pole is to be 21 feet from the starting line. Poles are 6 feet high and set on top of the ground, with bases 10 inches to 14 inches in diameter.

Contestants may start on either side of the line of poles. They will cross the starting line, move in an approximately straight line to pole 6 (the farthest pole), make a 180-degree turn around pole 6, pass between pole 6 and pole 5, bend through the poles to pole 1, circle pole 1, bend through the poles to pole 6, make a 180-degree turn around pole 6, and cross the starting line by moving along the poles on the side opposite that on which they first approached pole 6.

A 5-second penalty will be assessed for each pole knocked down.

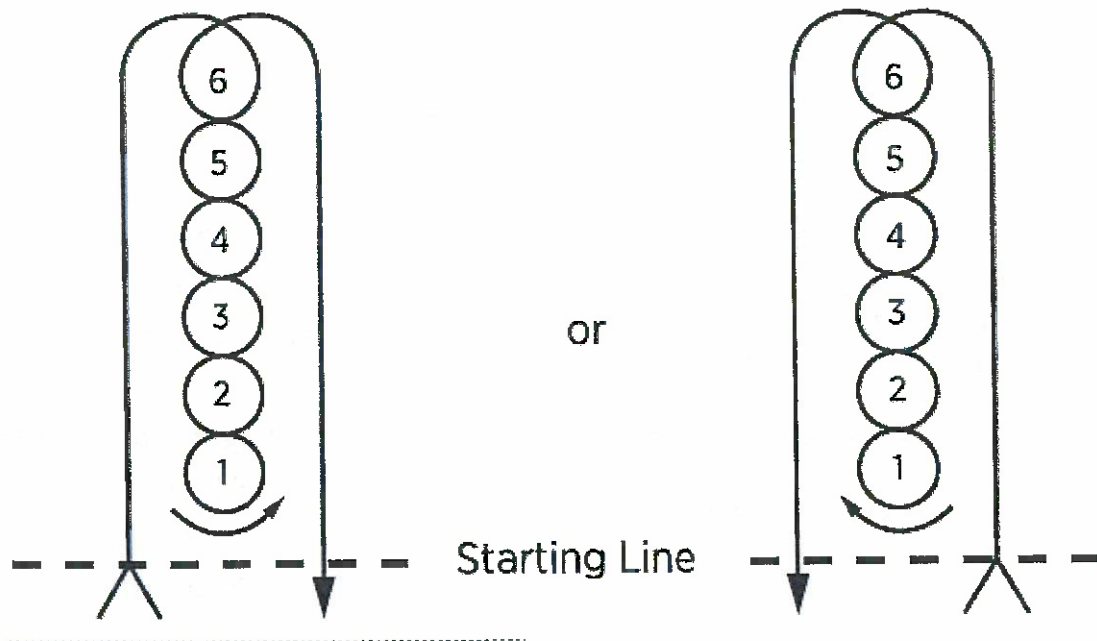

Van Buren Youth Fair

CLOVERLEAF BARREL RACE

Class #573, #574, #575, #576, #577, #578

Show Date: July 18, 2024

Barrels should be the size of a 55-gallon drum, with no sharp edges. Each barrel should be painted so that it can be easily distinguished from the background. Protective devices around steel barrel tops are required. The size of the pattern (see fig. 22) should be 105 feet (35 yards) between barrels 1 and 2, 120 feet (40 yards) between barrels 2 and 3, 120 feet (40 yards) between barrels 1 and 3, and 75 feet (25 yards) from the timer to the first barrel. The course must be measured exactly.

If the course is too large for the available space, then each measurement of the pattern should be reduced 15 feet (3 yards) from the fence. If the course specified in this rule book is too big for the available space, the distance from barrel 3 to the finish line need not be reduced 15 feet at a time, as long as there is enough room for the horse to stop safely.

Riders have the option of riding course A or B.

Course A—The entry must cross the timing line, circle barrel 1 clockwise, circle barrel 2 counterclockwise, circle barrel 3 counterclockwise, and run between barrels 2 and 3 to cross the timing line.

Course B—The entry must cross the timing line, circle barrel 2 counterclockwise, circle barrel 1 clockwise, circle barrel 3 clockwise, and run between barrels 2 and 3 to cross the timing line.

A 5-second penalty will be assessed for each barrel knocked down.

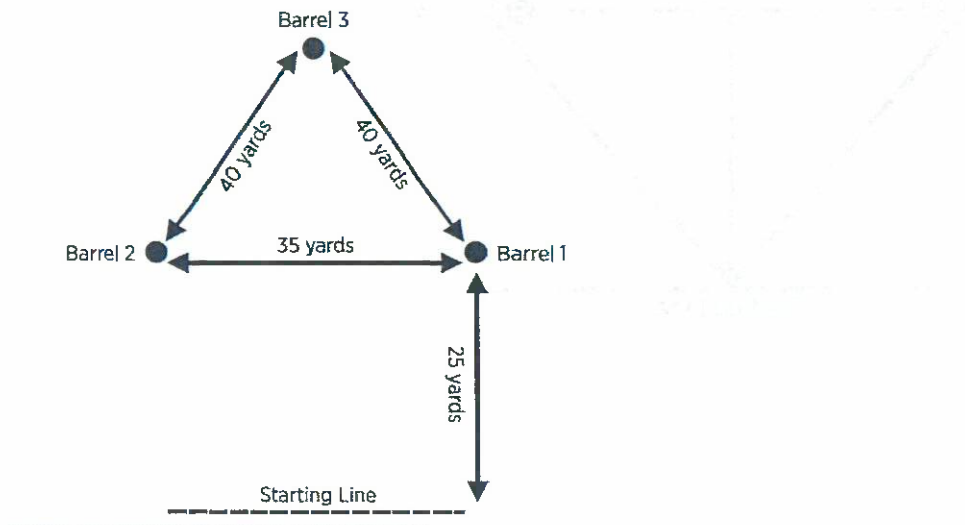

Van Buren Youth Fair

FLAG RACE

Class #579, #580, #581, #582, #583

Show Date: July 18, 2024

The course is set up in the same manner as for the Clover-leaf Barrel Race. Two 5-gallon buckets filled with approximately 4 inches of sand should be placed on the centers of the first and third barrels. The length of the flag sticks should be 12 inches to 16 inches above the edge of the bucket. Wooden dowelling $\frac{3}{4}$ inch in diameter, or other round suitable material, should be used for the flag.

The rider will pick up a flag at 1, ride behind 2, and place the flag in the bucket at barrel 3. Riders have the option of riding course A or B:

Course A—The entry will cross the starting line and begin following the pattern to the left.

Course B—The entry will cross the starting line and begin following the pattern to the right.

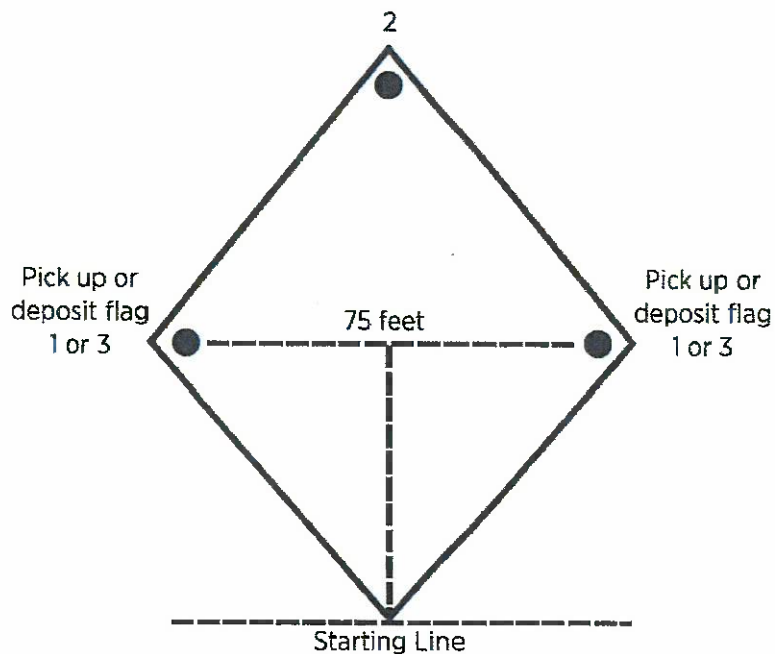

Van Buren Youth Fair

Walk-Trot, HRH, Pee Wee, In-Hand (will trot at all lopes) Class No: 586, 587, 588, and 589

Jr. and Sr. Trail Class No: 590 and 591

Show Date: Friday, July 19, 2024

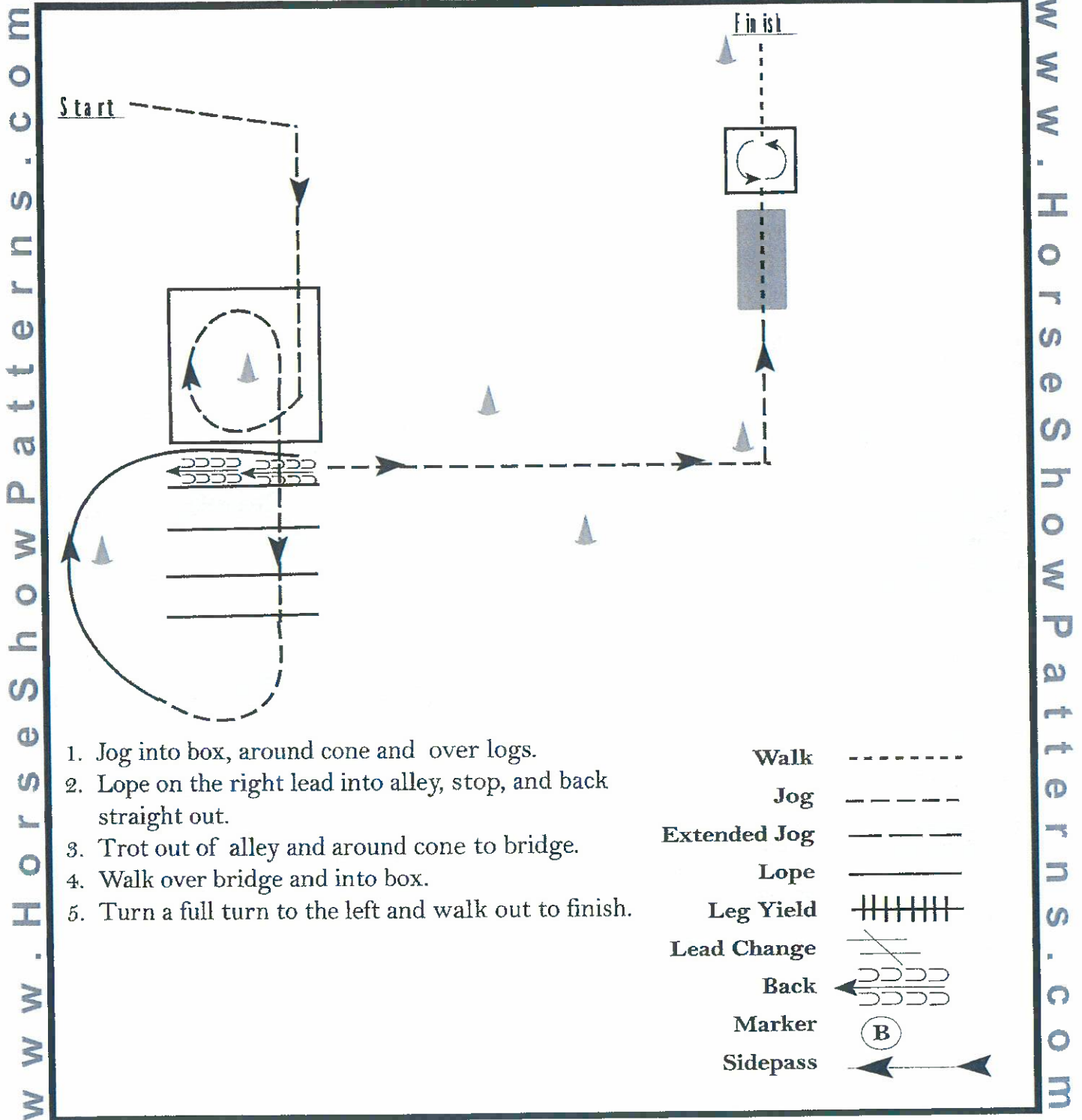

1. Jog into box, around cone and over logs.
2. Lope on the right lead into alley, stop, and back straight out.
3. Trot out of alley and around cone to bridge.
4. Walk over bridge and into box.
5. Turn a full turn to the left and walk out to finish.

Walk	-----
Jog	- - - - -
Extended Jog	- . - . -
Lope	—————
Leg Yield	
Lead Change	///
Back	←———
Marker	ⓑ
Sidepass	←———→

[T/1-28]

Pattern Provided by: Van Buren County Horse Committee

Van Buren Youth Fair

Class # 592

(Reining on even years)

Show Day: July 19, 2024

REINING PATTERN 2

Exhibitors may walk or trot their horses to the center of the arena. Horses must walk or stop before starting the pattern. Begin at the center of the arena facing the left wall or fence. (See fig. 19 for a diagram of reining pattern 2.)

1. Complete one spin to the right. Hesitate.
2. Complete one spin to the left. Hesitate.
3. Beginning on the left lead, complete two circles to the left, with the first circle large and fast, and the second circle small and slow. Change leads at the center of the arena.
4. Complete two circles to the right, with the first circle large and fast, and the second circle small and slow. Change leads at the center of the arena.
5. Begin a large fast circle to the left but do not close this circle. Run up the right side of the arena past the center marker and do a right rollback at least 20 feet (6 meters) from the wall or fence—no hesitation.
6. Continue back around the previous circle but do not close this circle. Run up the left side of the arena past the center marker and do a left rollback at least 20 feet (6 meters) from the wall or fence—no hesitation.
7. Continue back around previous circle but do not close this circle. Run up the right side of the arena past the center marker and do a sliding stop at least 20 feet (6 meters) from the wall or fence. Back up at least 10 feet (3 meters). Hesitate to demonstrate that you have completed the pattern.
8. Dismount and drop the bridle to the designated judge.

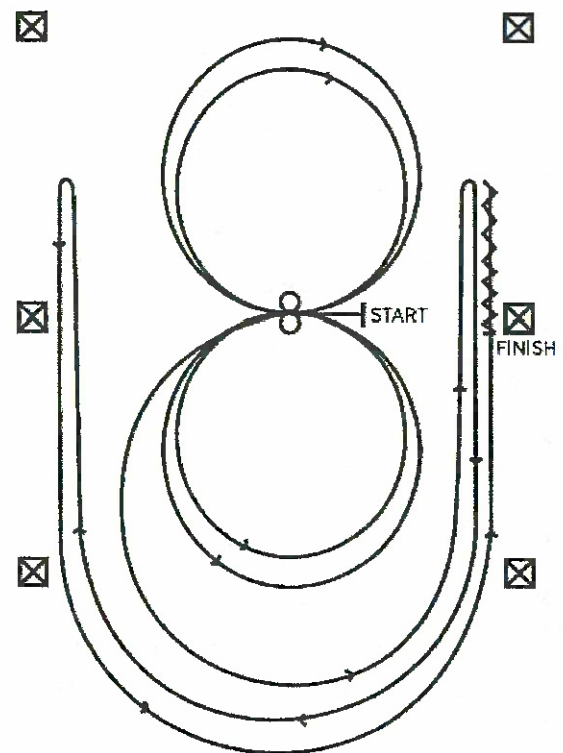

Figure 19. Reining pattern 2.